

JET

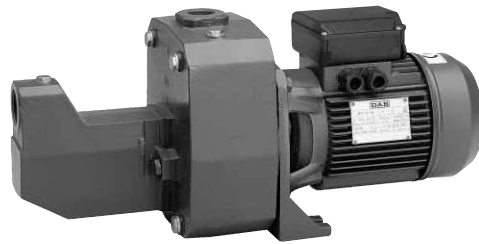

JET 200-300



JET 62-82-102-112-92-132



JET 151-251



GENERAL DATA

Applications

Self-priming centrifugal pump with excellent suction capacity even when there are air bubbles and small particles of sand in the water.

Used especially for supplying water to domestic installations. Ideal for use in small-scale agriculture and gardening, limited industrial services and wherever self-priming operation is necessary.

Constructional features of the pump

Cast iron pump body and motor support.

Motor support in die-cast aluminium for Jet 62-82-102-112-92-132.

Technopolymer impeller, diffuser, Venturi tube and sand guard.

Stainless steel pressure discs.

Carbon/ceramic mechanical seal.

Constructional features of the motor

Induction motor, closed and cooled with external ventilation.

Rotor mounted on oversized greased sealed-for-life ball bearings to ensure silent running and long life.

Built-in thermal and current overload protection and a capacitor permanently in circuit in the single-phase version.

Three-phase motors should be protected with a suitable overload protection complying with the regulations in force.

Manufactured according to CEI 2-3 and CEI 61-69 standards (EN 60335-2-41).

Motor protection: IP 44

Terminal box protection: IP 55

Insulation class: F

Standard voltage: single-phase 220-240 V/50 Hz
 three-phase 230-400 V/50 Hz

TECHNICAL DATA

N.	PARTS*	MATERIALS	MODELS
1	PUMP BODY	CAST IRON 200 UNI ISO 185	
3	SUPPORT	CAST IRON 200 UNI ISO 185 DIE-CAST ALUMINIUM	JET 151; 251; 200; 300 JET 62; 82; 102; 112; 92; 132
4	IMPELLER	TECHNOPOLYMER A	
7	SHAFT WITH ROTOR	STAINLESS STEEL AISI 416 X12 CrS13 - UNI 6900/71	
16	MECHANICAL SEAL	CARBON/CERAMIC	
28	OR GASKET	NBR RUBBER	
160	NOZZLE-VENTURI DIFFUSER ASSEMBLY	TECHNOPOLYMER A	

* In contact with the liquid.

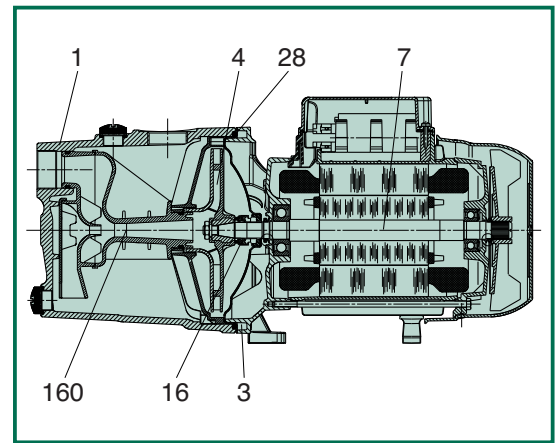

Self priming capacity

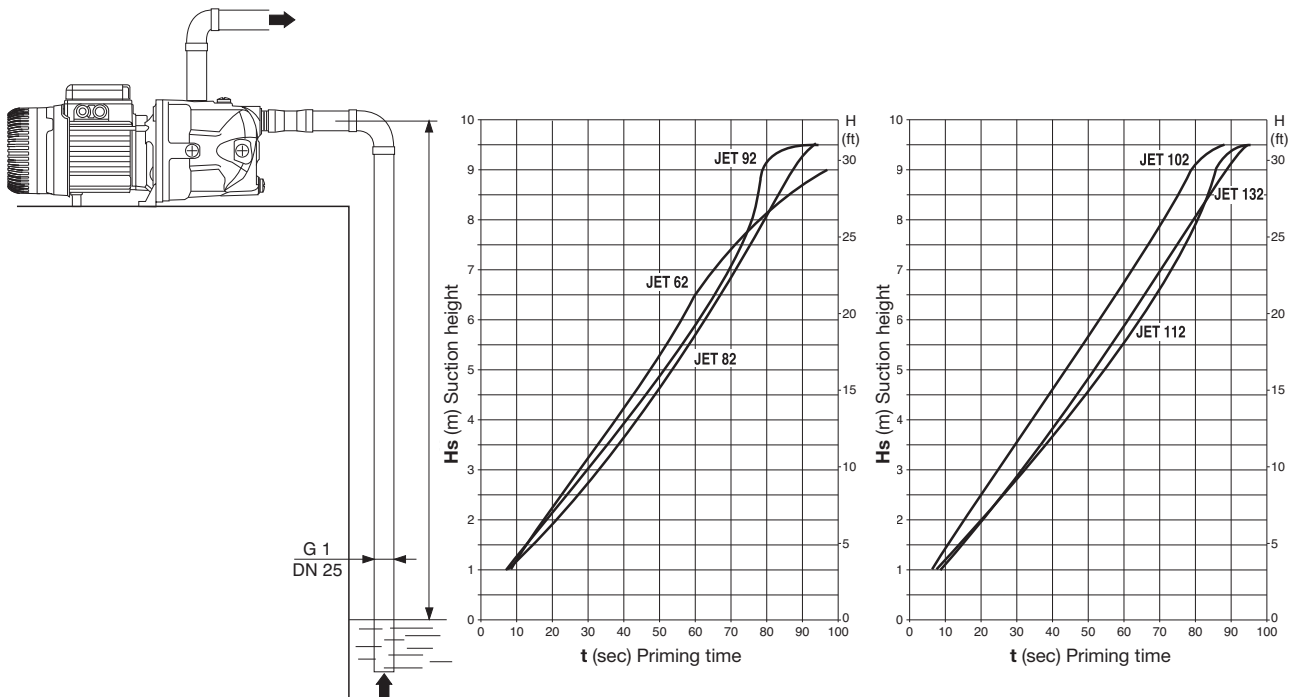

- Operating range: from 0,4 to 10,5 m³/h with head up to 62 metres
- Liquid quality requirements: clean, free from solids or abrasive substances, non viscous, non aggressive, non crystallized, chemically neutral, close to the characteristics of water.
- Liquid temperature range: from 0°C to +35°C for domestic use (EN 60335-2-41)
from 0°C to +40°C for other uses
- Maximum ambient temperature: +40°C
- Maximum operating pressure: 8 bar (800 kPa)
- Installation: fixed in a horizontal position
- Special executions on request: other voltages and/or frequencies

The performance curves are based on the kinematic viscosity values = 1 mm²/s and density equal to 1000 kg/m³. Curve tolerance according to ISO 9906.

Liquid temperature range: from 0 °C to +35°C

Maximum ambient temperature: +40°C

JET 62

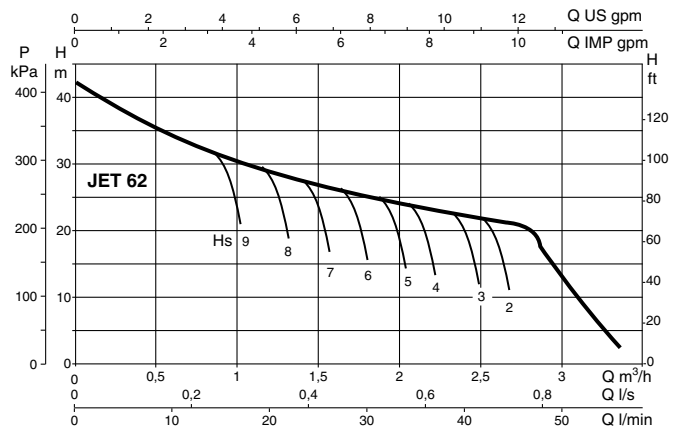
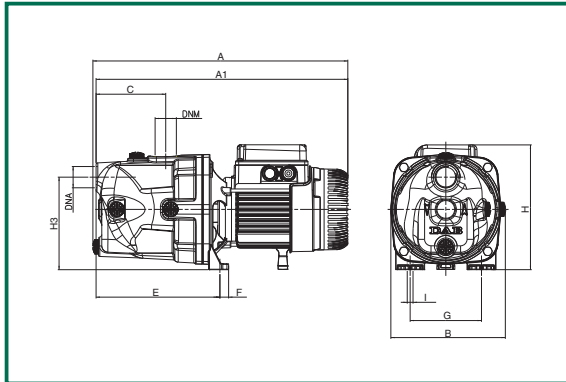

MODEL	A	A1	B	C	E	F	G	H	H3	I	DNA	DNM	PACKING DIMENSIONS			VOLUME	WEIGHT
													L/A	L/B	H	m ³	Kg
JET 62	395	390	178	108	192	14	111	193	144	9	1" G	1" G	470	240	240	0,022	10,5

MODEL	ELECTRICAL DATA						HYDRAULIC DATA (n ≈ 2850 1/min)								
	VOLTAGE 50 Hz	P1 MAX kW	P2 NOMINAL		In A	CAPACITOR	Q m ³ /h	0	0,6	1,2	1,8	2,4	2,7	3,6	
			kW	HP		μF	Vc	l/min	0	10	20	30	40	45	60
JET 62 M	1x220-240 V ~	0,72	0,44	0,6	3,12	12,5	450	H (m)	42	35	29,2	25,6	22,9	21,1	-
JET 62 T	3x230-400 V ~	0,67	0,44	0,6	2,1-1,2	-	-								

JET 82

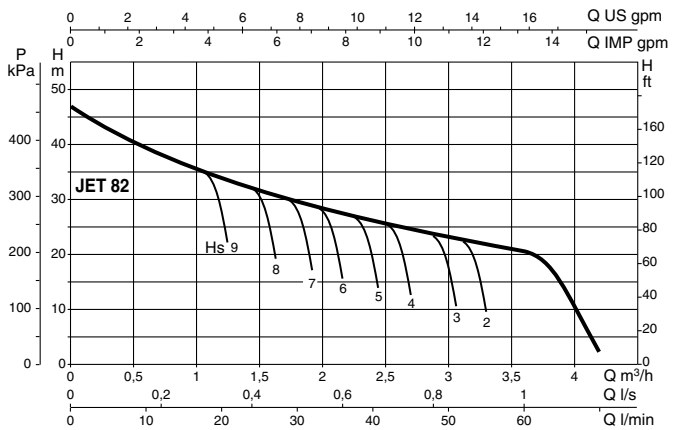
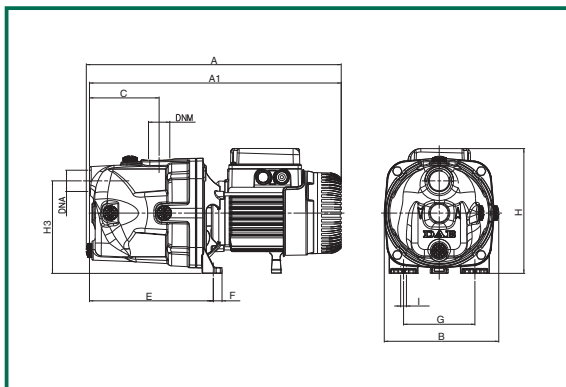

MODEL	A	A1	B	C	E	F	G	H	H3	I	DNA	DNM	PACKING DIMENSIONS			VOLUME	WEIGHT
													L/A	L/B	H	m ³	Kg
JET 82	395	395	178	108	192	14	111	193	144	9	1" G	1" G	470	240	240	0,022	10,7

MODEL	ELECTRICAL DATA						HYDRAULIC DATA (n ≈ 2750 1/min)								
	VOLTAGE 50 Hz	P1 MAX kW	P2 NOMINAL		In A	CAPACITOR	Q m ³ /h	0	0,6	1,2	1,8	2,4	3	3,6	
			kW	HP		μF	Vc	l/min	0	10	20	30	40	50	60
JET 82 M	1x220-240 V ~	0,85	0,6	0,8	3,2	12,5	450	H (m)	47	40	34	30	26,2	23,5	20,3
JET 82 T	3x230-400 V ~	0,86	0,6	0,8	2,8-1,6	-	-								

The performance curves are based on the kinematic viscosity values = 1 mm²/s and density equal to 1000 kg/m³. Curve tolerance according to ISO 9906.
 Liquid temperature range: from 0 °C to +35°C
 Maximum ambient temperature: +40°C

JET 102

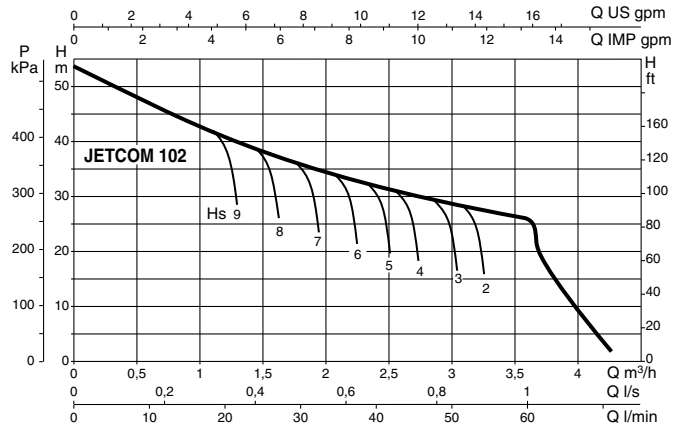
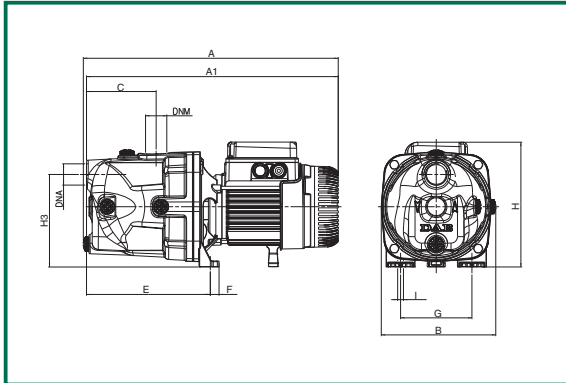

MODEL	A	A1	B	C	E	F	G	H	H3	I	DNA	DNM	PACKING DIMENSIONS			VOLUME m ³	WEIGHT Kg
													L/A	L/B	H		
JET 102	414	409	178	108	197	14	111	203	144	9	1" G	1" G	470	240	240	0,022	12,5

MODEL	ELECTRICAL DATA						HYDRAULIC DATA (n ≈ 2800 1/min)								
	VOLTAGE 50 Hz	P1 MAX kW	P2 NOMINAL		In A	CAPACITOR μF Vc	Q								
			kW	HP			m ³ /h	l/min	0	0,6	1,2	1,8	2,4	3	3,6
JET 102 M	1x220-240 V ~	1,13	0,75	1	5,1	16	450	H (m)	53,8	47	41	36,3	32,4	28,8	25,8
JET 102 T	3x230-400 V ~	1,04	0,75	1	3,3-1,9	-	-								

JET 112

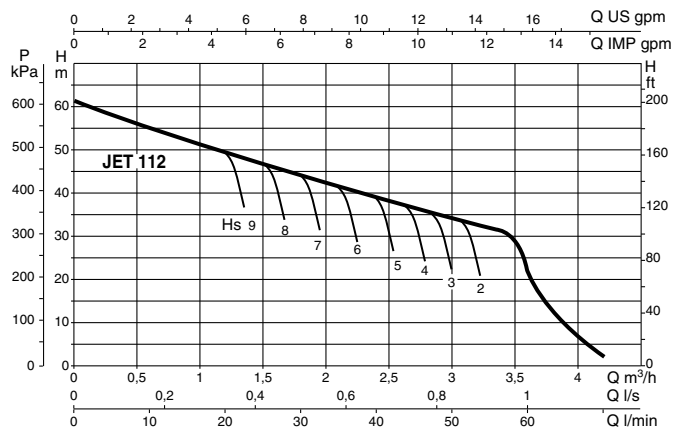
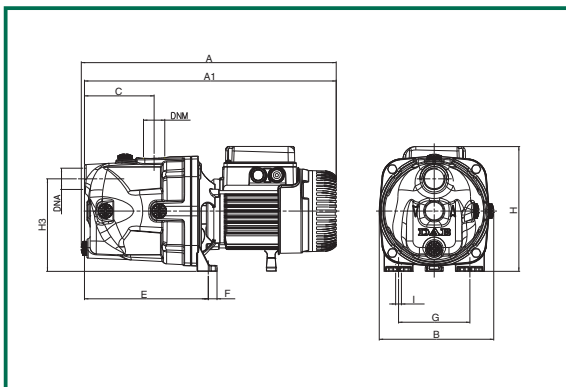

MODEL	A	A1	B	C	E	F	G	H	H3	I	DNA	DNM	PACKING DIMENSIONS			VOLUME m ³	WEIGHT Kg
													L/A	L/B	H		
JET 112	414	409	178	108	192	14	111	203	144	9	1" G	1" G	470	240	240	0,022	13,5

MODEL	ELECTRICAL DATA						HYDRAULIC DATA (n ≈ 2750 1/min)								
	VOLTAGE 50 Hz	P1 MAX kW	P2 NOMINAL		In A	CAPACITOR μF Vc	Q								
			kW	HP			m ³ /h	l/min	0	0,6	1,2	1,8	2,4	3	3,6
JET 112 M	1x220-240 V ~	1,4	1	1,36	6,2	25	450	H (m)	61	54	47,8	42,8	38,8	34,8	20
JET 112 T	3x230-400 V ~	1,35	1	1,36	4,3-2,5	-	-								

The performance curves are based on the kinematic viscosity values = 1 mm²/s and density equal to 1000 kg/m³. Curve tolerance according to ISO 9906.

Liquid temperature range: from 0 °C to +35°C
 Maximum ambient temperature: +40°C

JET 92

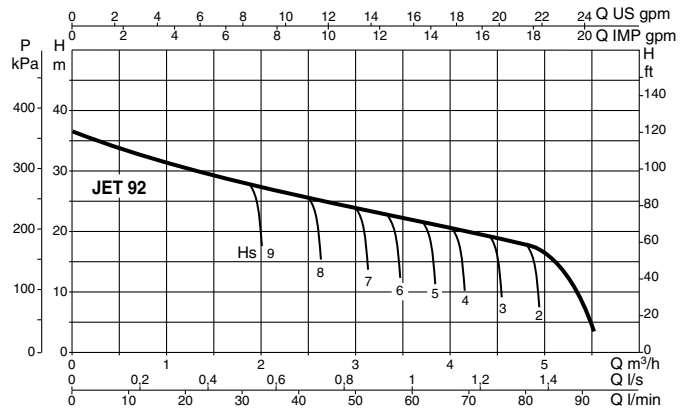
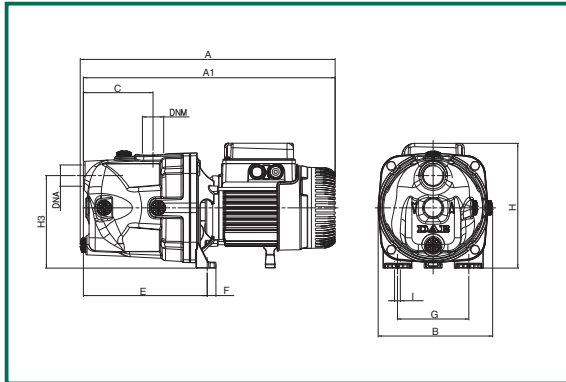

MODEL	A	A1	B	C	E	F	G	H	H3	I	DNA	DNM	PACKING DIMENSIONS			VOLUME m ³	WEIGHT Kg
													L/A	L/B	H		
JET 92	395	390	178	108	192	14	111	193	144	9	1" G	1" G	470	240	240	0,022	11,7

MODEL	ELECTRICAL DATA						HYDRAULIC DATA (n ≈ 2750 1/min)										
	VOLTAGE 50 Hz	P1 MAX kW	P2 NOMINAL		In A	CAPACITOR		Q									
			kW	HP		μF	Vc	m ³ /h	0	0,6	1,2	1,8	2,4	3	3,6	4,2	4,8
JET 92 M	1x220-240 V ~	0,94	0,75	1	4,2	14	450	H	36,2	33,5	31	28,4	26	24	21,8	19,6	17
JET 92 T	3x230-400 V ~	0,93	0,75	1	3,3-1,9	-	-	(m)									

JET 132

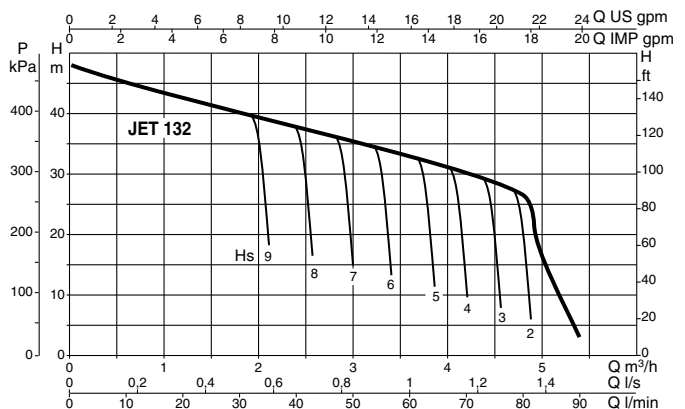
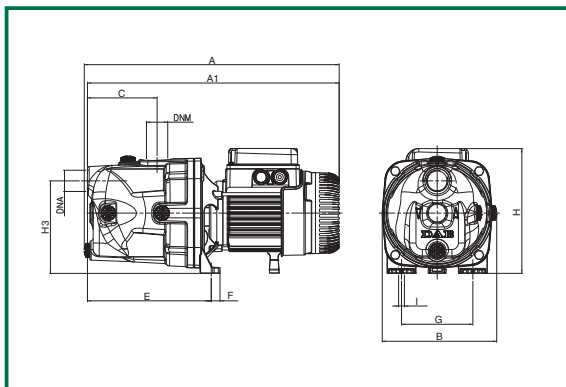

MODEL	A	A1	B	C	E	F	G	H	H3	I	DNA	DNM	PACKING DIMENSIONS			VOLUME m ³	WEIGHT Kg
													L/A	L/B	H		
JET 132	414	409	263	108	192	14	111	203	144	9	1" G	1" G	470	240	240	0,022	13,5

MODEL	ELECTRICAL DATA						HYDRAULIC DATA (n ≈ 2750 1/min)										
	VOLTAGE 50 Hz	P1 MAX kW	P2 NOMINAL		In A	CAPACITOR		Q									
			kW	HP		μF	Vc	m ³ /h	0	0,6	1,2	1,8	2,4	3	3,6	4,2	4,8
JET 132 M	1x220-240 V ~	1,49	1	1,36	6,6	25	450	H	48	45,6	42,8	40	37,6	35	32,5	30	27
JET 132 T	3x230-400 V ~	1,43	1	1,36	4,7-2,7	-	-	(m)									

The performance curves are based on the kinematic viscosity values = 1 mm²/s and density equal to 1000 kg/m³. Curve tolerance according to ISO 9906.

Liquid temperature range: from 0 °C to +35°C
 Maximum ambient temperature: +40°C

JET 151

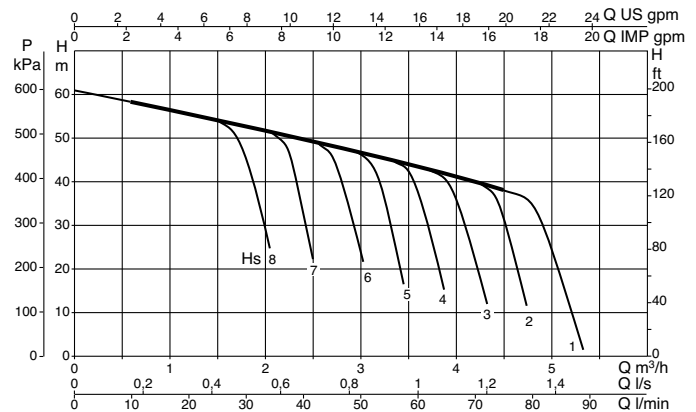
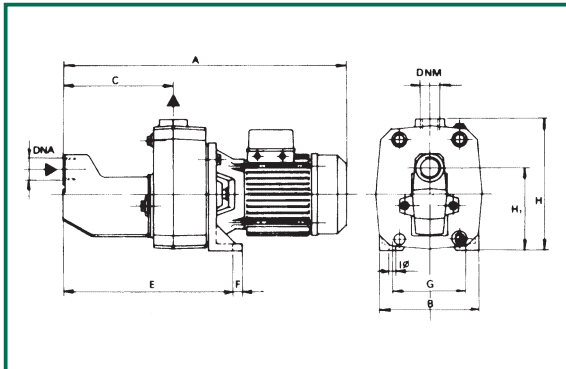

MODEL	A	B	C	E	F	G	I Ø	H	H1	DNA	DNM	PACKING DIMENSIONS			VOLUME	WEIGHT
												L/A	L/B	H	m ³	Kg
JET 151	558	210	221	350	20	145	11	255	158	1 1/4" G	1" G	612	248	279	0,042	31

MODEL	ELECTRICAL DATA						HYDRAULIC DATA (n ≈ 2800 1/min)												
	VOLTAGE 50 Hz	P1 MAX kW	P2 NOMINAL		In A	CAPACITOR	Q												
			kW	HP		μF	Vc	m ³ /h	l/min	0	0,6	1,2	1,8	2,4	3	3,6	4,2	4,5	
JET 151 M	1x220-240 V ~	1,6	1,1	1,5	7,2	31,5	450	H	(m)	61	58,2	56	53	50	46	43	39,5	36	
JET 151 T	3x230-400 V ~	1,6	1,1	1,5	5,2-3	-	-												

JET 251

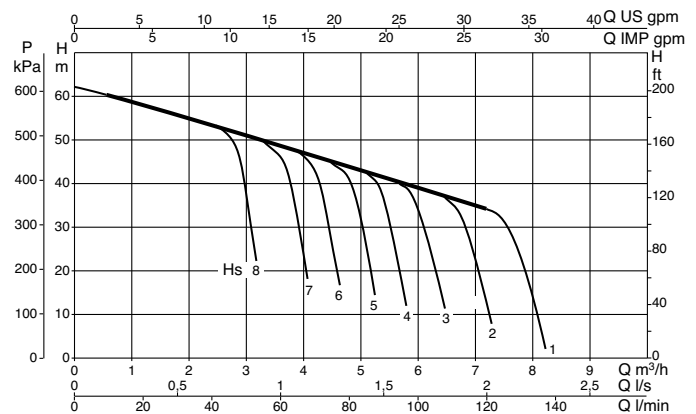
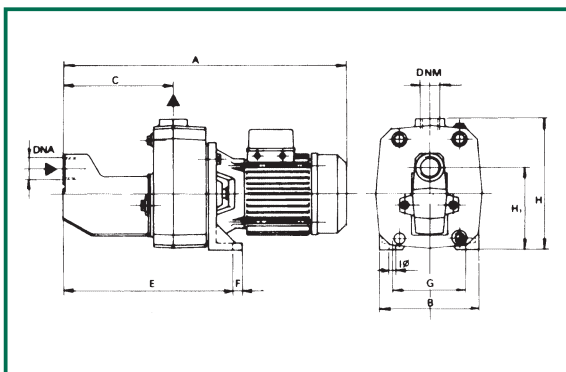

MODEL	A	B	C	E	F	G	I Ø	H	H1	DNA	DNM	PACKING DIMENSIONS			VOLUME	WEIGHT
												L/A	L/B	H	m ³	Kg
JET 251 M	632	210	221	350	20	145	11	255	158	1 1/4" G	1" G	657	248	279	0,045	35
JET 251 T	558	210	221	350	20	145	11	255	158	1 1/4" G	1" G	612	248	279	0,042	31

MODEL	ELECTRICAL DATA						HYDRAULIC DATA (n ≈ 2800 1/min)													
	VOLTAGE 50 Hz	P1 MAX kW	P2 NOMINAL		In A	CAPACITOR	Q													
			kW	HP		μF	Vc	m ³ /h	l/min	0	0,6	1,2	1,8	2,4	3	3,6	4,2	4,5	6	7,2
JET 251 M	1x220-240 V ~	2,2	1,85	2,5	10	40	450	H	(m)	62	60	58	56	54	51	48,5	46	43,5	39	34,2
JET 251 T	3x230-400 V ~	2,2	1,85	2,5	6,9-4	-	-													

The performance curves are based on the kinematic viscosity values = 1 mm²/s and density equal to 1000 kg/m³. Curve tolerance according to ISO 9906.

Liquid temperature range: from 0 °C to +35°C
 Maximum ambient temperature: +40°C

JET 200

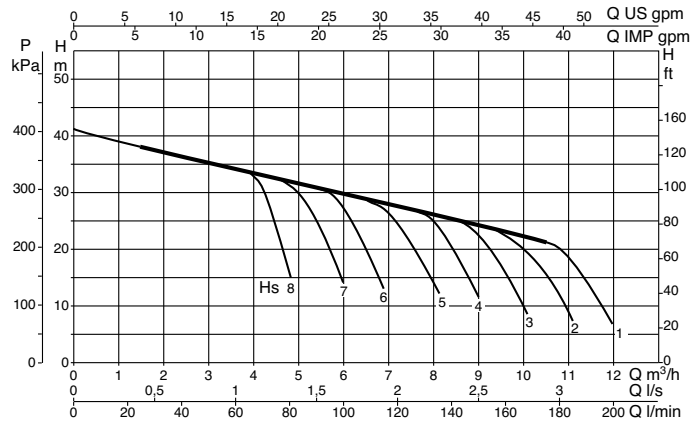
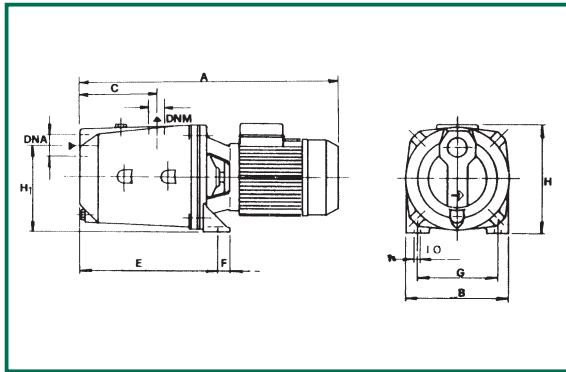

MODEL	A	B	C	E	F	G	I Ø	H	H1	DNA	DNM	PACKING DIMENSIONS			VOLUME m ³	WEIGHT Kg
												L/A	L/B	H		
JET 200	521	214	151	282	20	160	11	227	175	1 1/2" G	1 1/4" G	612	248	279	0,042	27

MODEL	ELECTRICAL DATA						HYDRAULIC DATA (n = 2850 1/min)										
	VOLTAGE 50 Hz	P1 MAX kW	P2 NOMINAL		In A	CAPACITOR		Q									
			kW	HP		µF	Vc	m ³ /h	0	1,5	2,4	3,6	4,8	6	7,2	9	10,5
JET 200 M	1x220-240 V ~	2,0	1,5	2	9	31,5	450	H	41	38	36,5	34	31,8	29,5	27,2	24	21,3
JET 200 T	3x230-400 V ~	2,0	1,5	2	6,8-3,9	-	-	(m)	46,5	43,5	41,8	39,2	37	34,2	31,8	28	25

JET 300

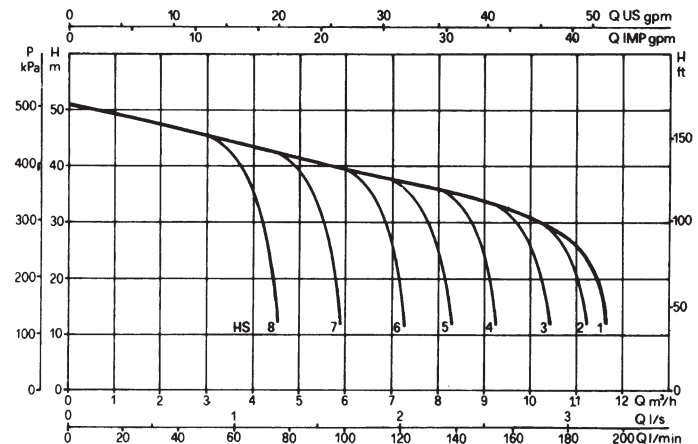
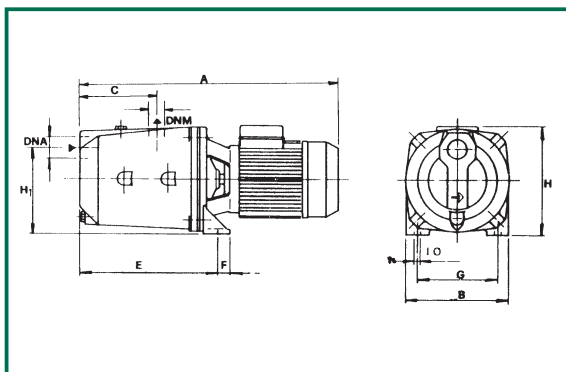

MODEL	A	B	C	E	F	G	I Ø	H	H1	DNA	DNM	PACKING DIMENSIONS			VOLUME m ³	WEIGHT Kg
												L/A	L/B	H		
JET 300 M	595	214	151	282	20	160	11	235	175	1 1/2" G	1 1/4" G	657	248	279	0,045	31,5
JET 300 T	521	214	151	282	20	160	11	227	175	1 1/2" G	1 1/4" G	612	248	279	0,042	27

MODEL	ELECTRICAL DATA						HYDRAULIC DATA (n = 2850 1/min)											
	VOLTAGE 50 Hz	P1 MAX kW	P2 NOMINAL		In A	CAPACITOR		Q										
			kW	HP		µF	Vc	m ³ /h	0	1,5	1,8	2,4	3,6	4,8	6	7,2	9	10,5
JET 300 M	1x220-240 V ~	2,7	2,2	3	12	40	450	H	51	49	48	47	44,5	42	40	37	33	29
JET 300 T	3x230-400 V ~	2,5	2,2	3	8,5-4,9	-	-	(m)	51	49	48	47	44,5	42	40	37	33	29